

In - Line Fixture Kit

INLINE FIXTURE FOR 6TL HANDLER WITH VPC G25

Equip **ILFS-6TL-VPC-G25** In - Line Fixture

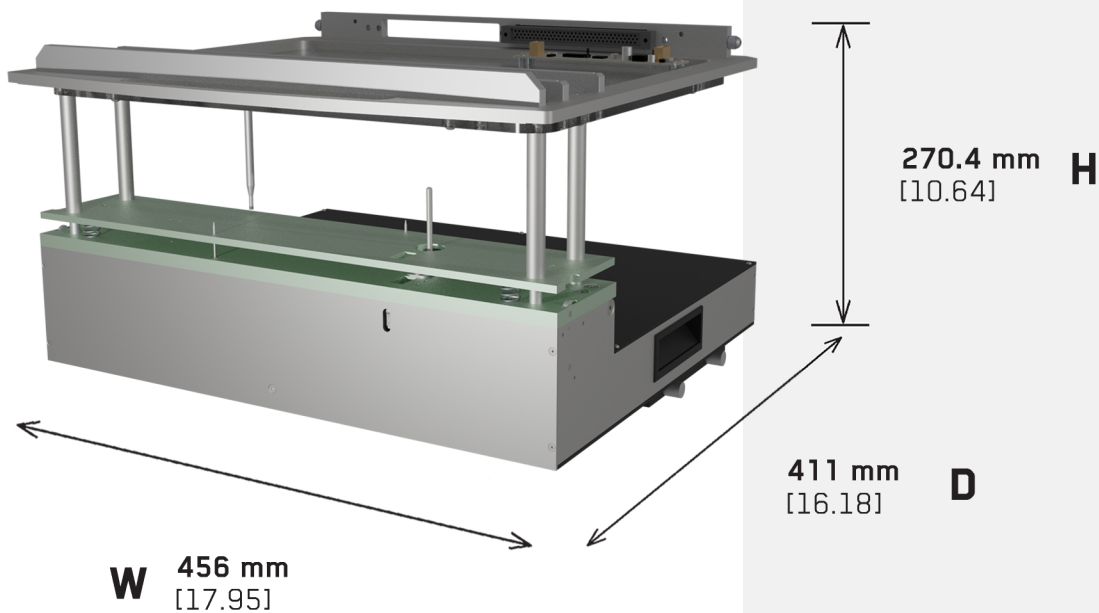

Technical Features:

- External Dimension (width x depth x height) with Handles:
456 mm x 411 mm x 270.4 mm
[17.95 in x 16.18 in x 10.64 in]
- Useable Area: 410 mm x 384 mm [16.14 in x 15.12 in]
- Top and Bottom test
- Installation height of test probes:
bottom - 16 mm, top - 16 mm
- Maximum 640 channels

